



MICRO B

DC BRUSHLESS SERVODRIVE



MICRO B[®] (MCB)

Micro Dc Brushless Servodrive for 60V servomotors up to 1.5 Nm (212 oz.-in.)

Typical application are :
 Conveyors, Medical, Textile Equipment,
 Packaging Machinery, Positioners, Converting Machinery,
 X-Y Stages, Automated Assembly Machinery, Robotics,
 Component Insertion Machines.

STANDARD FEATURES

- ✓ Three phase trapezoidal brushless, four quadrant operation
- ✓ Panel mount
- ✓ Highly efficient and reliable power MOSFET output stage
- ✓ Single DC power supply
- ✓ Three velocity feedback modes:
 - Hall Feedback
 - Armature Feedback
 - Encoder Feedback + Hall Signals
- ✓ Ixt function
- ✓ Five LED (Red/Green) indicating operating status
- ✓ Fully protected against:
 - External short circuit - Over/under voltage
 - Overtemperature - Hall Signal absence
- ✓ Wide load inductance range (1 - 30 mH)
- ✓ 60/120 degree commutation phase setting
- ✓ Four adjusting potentiometers
- ✓ Extractable screw terminals
- ✓ Enable input available with both positive/negative logical levels

OPTIONS

- ✓ PWM+Direction mode

SPECIFICATIONS

- ✓ Supply voltage range 20÷82 Vdc
- ✓ Operating frequency 20 KHz
- ✓ Operating temperature 0÷40 °C (32÷104°F)
- ✓ Input reference (differential) ±10V
- ✓ Motor current monitor ±7,5V (At peak current)
- ✓ Auxiliary output supply for encoder +5V@130mA
- ✓ Enable signals +10÷30Vdc
- ✓ Output voltage supply +10V/-10V@4mA



DESCRIPTION

The MICRO B[®] drives have been designed as ultra compact modules, suitable for all industrial automation requirements. They are the ideal solution for incremental motion control, velocity loop and positioning systems which require fast response, high torque at low speed, smooth speed control and high reliability.

ACCESSORIES

(see specific data sheets for details)

- ✓ **SERVOMOTORS**
 - Ssax 1000/2000: 0.35÷1.3Nm (50÷186 oz.-in.)
- ✓ **GEARBOXES**
 - Rex 100: 5 flange sizes, R ratios 1/3÷1/216
- ✓ **POWER SUPPLY (stand alone)**
 - MPPlus: 63÷200 Vdc out, 30 Adc, 100÷800W braking power
- ✓ **TRANSFORMERS**
 - TM/TT: single/3ph 100÷8000 VA
- ✓ **NET FILTERS (for CE compliance)**
 - FRM/FRT: single/3ph, 2÷16 Arms

| MODEL | MCB 60 | | | |
|--|--------------|------|------|-------|
| SIZE (A) | 2.5/5 | 5/10 | 8/16 | 10/20 |
| CASE | PM1 | PM1 | PM1 | PM1 |
| Nominal Current (A _{dc}) | 2.5 | 5 | 8 | 10 |
| Peak Current (A _{dc}) x 2 sec. | 5 | 10 | 16 | 20 |
| FDC: Supply Line Fuse (type F, M or T)* | 15 A / 250 V | | | |
| Supply (V _{dc}) | 63 Vdc ▲ | | | |

*: FDC Fuse Type: F=Quick-acting M= Medium time-lag T=Time-lag

▲: Recommended DC power supply

Drawings are not to scale (see quotations)

MECHANICAL DIMENSIONS

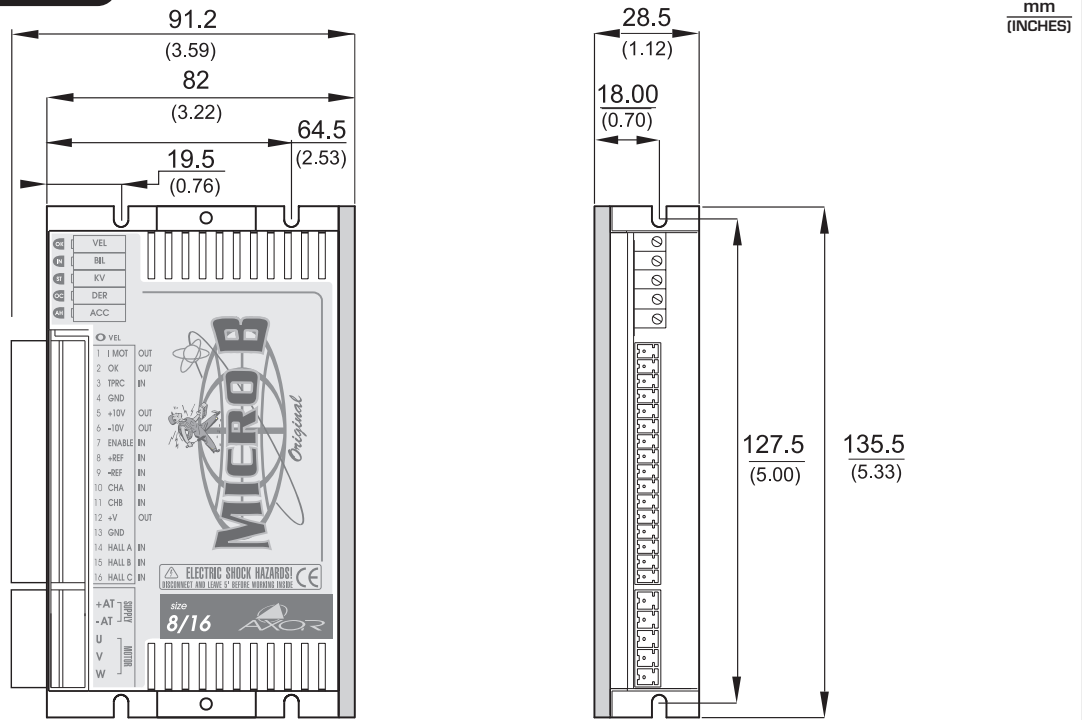

Weight: 0.35Kg

CASE PM1 (Panel Mount "1")

CONNECTION DIAGRAM

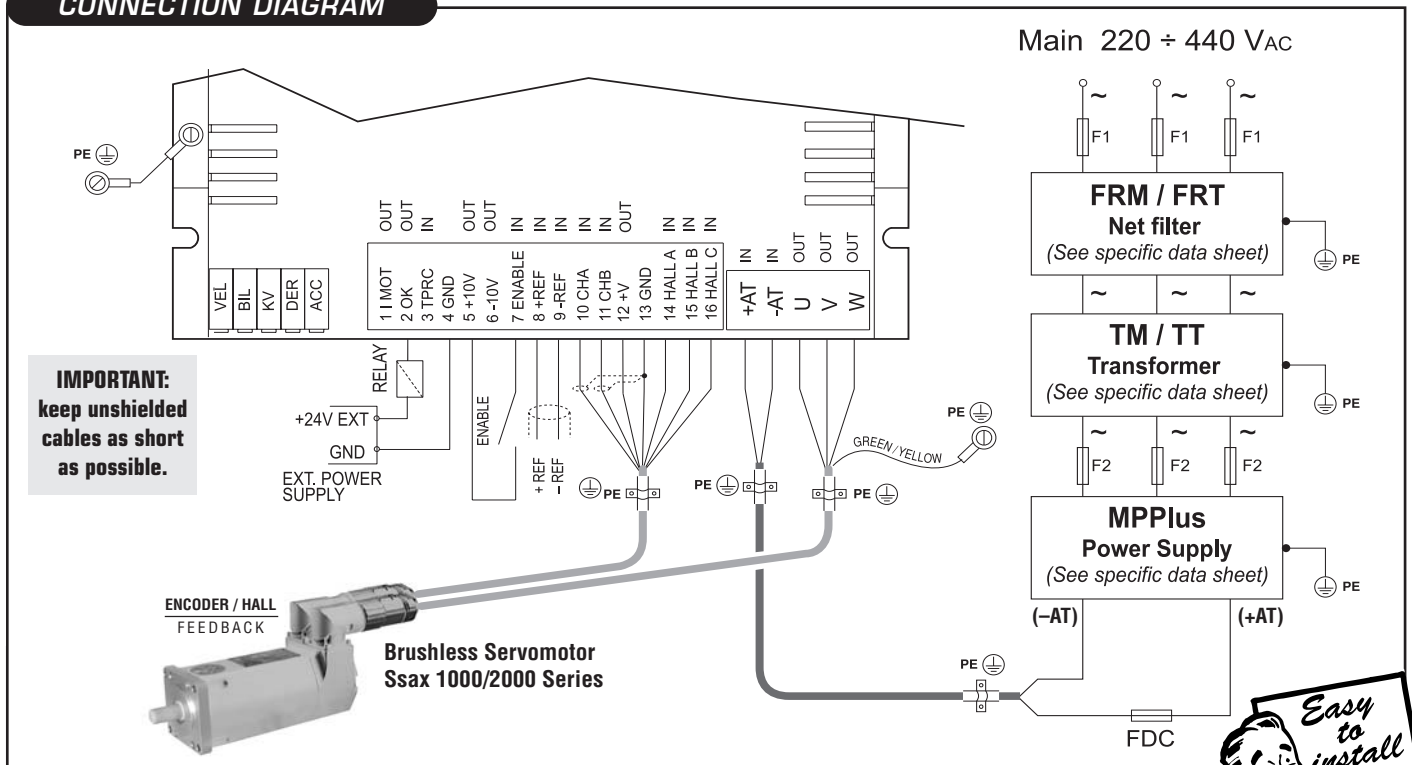

ORDERING CODE
Example:

MCB - 60 - 10 / 20 - N - S - 1000 / EC - RD

NAME: Line of Brushless Servodrives

AMPLIFIER TYPE: 060

SIZE: 2.5/05 - 05/10 - 08/16 - 10/20

HEATSINK VERSIONS:
N= Normal

PROTECTION:
S = Standard
T = Tropicalized

AXOR
adjustment
identification
number

CONTROL MODE:

RD= Differential reference
PD= PWM+Direct (option)
IO = Demand current (torque mode)

FEEDBACK:

AH = Armature+hall
EH = Encoder+external hall
HO = Hall (only)
EC = Commutation encoder
OO = No feedback adjustment (for IO and PD control modes)